

REV	REF	DATE	DRAWN BY
1	---	24.11.2006	DDE
2	ECO833	18.01.2007	DDE
2.1	ECO 901	30.11.2007	VNA

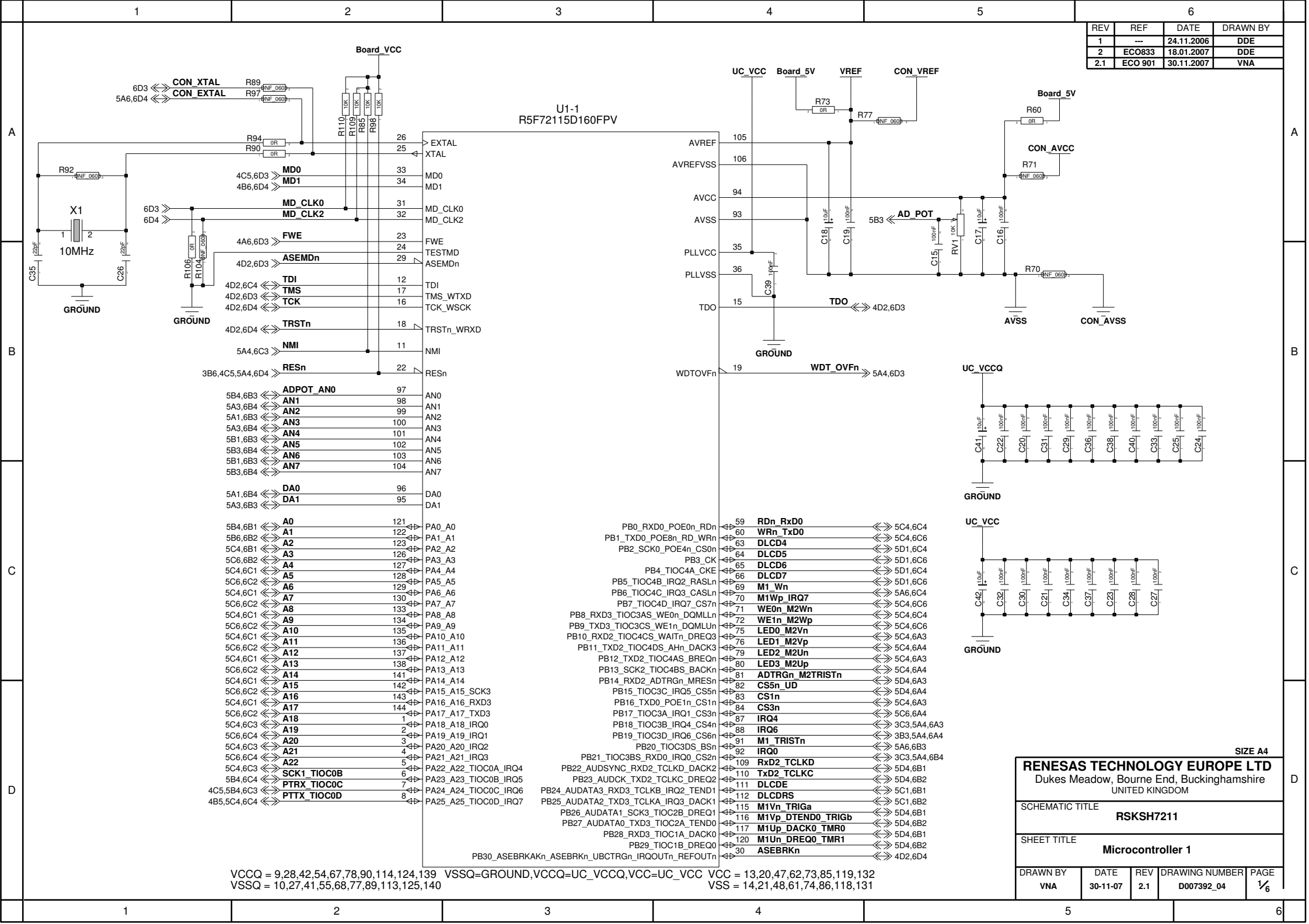

VCCQ = 9,28,42,54,67,78,90,114,124,139 VSSQ=GROUND,VCCQ=UC_VCCQ,VCC=UC_VCC VCC = 13,20,47,62,73,85,119,132
VSSQ = 10,27,41,55,68,77,89,113,125,140 VSS = 14,21,48,61,74,86,118,131

SIZE A4

RENESAS TECHNOLOGY EUROPE LTD
Dukes Meadow, Bourne End, Buckinghamshire
UNITED KINGDOM

SCHEMATIC TITLE
RSKSH7211

SHEET TITLE
Microcontroller 1

DRAWN BY VNA	DATE 30-11-07	REV 2.1	DRAWING NUMBER D007392_04	PAGE 1/6
-----------------	------------------	------------	------------------------------	-------------

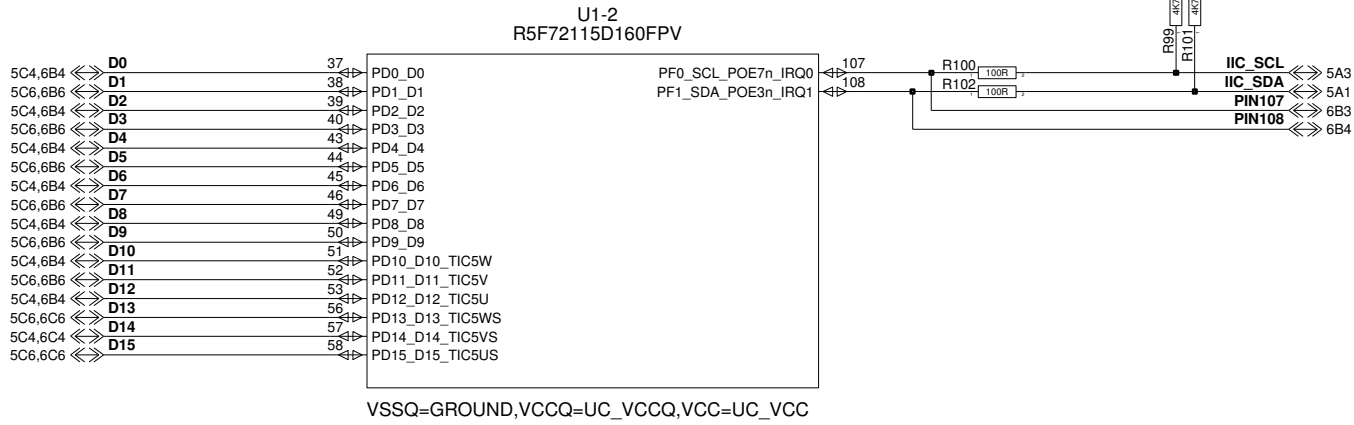

SIZE A4

RENESAS TECHNOLOGY EUROPE LTD
Dukes Meadow, Bourne End, Buckinghamshire
UNITED KINGDOM

SCHEMATIC TITLE
RSKSH7211

SHEET TITLE
Microcontroller 2

DRAWN BY VNA	DATE 30-11-07	REV 2.1	DRAWING NUMBER D007392_04	PAGE 2/6
-----------------	------------------	------------	------------------------------	-------------

POWER

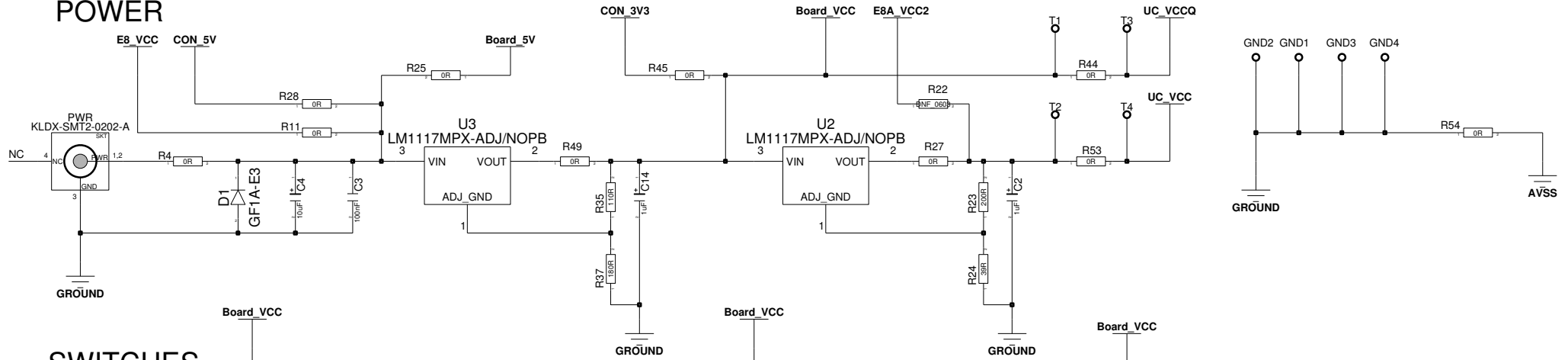

SWITCHES

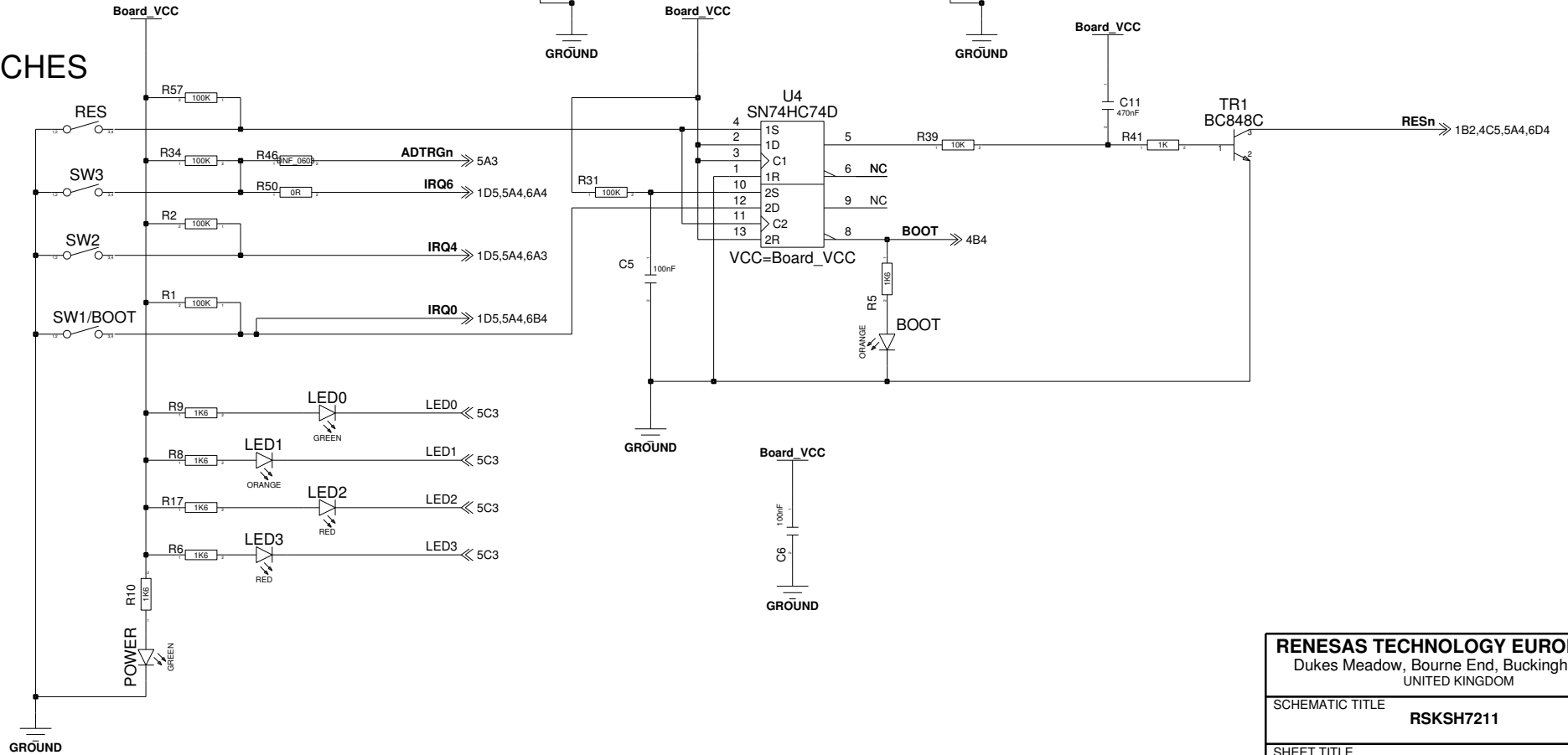

SIZE A4

RENESAS TECHNOLOGY EUROPE LTD
 Dukess Meadow, Bourne End, Buckinghamshire
 UNITED KINGDOM

SCHEMATIC TITLE
RSKSH7211

SHEET TITLE
Switches and PSU

DRAWN BY	DATE	REV	DRAWING NUMBER	PAGE
VNA	30-11-07	2.1	D007392_04	3/6

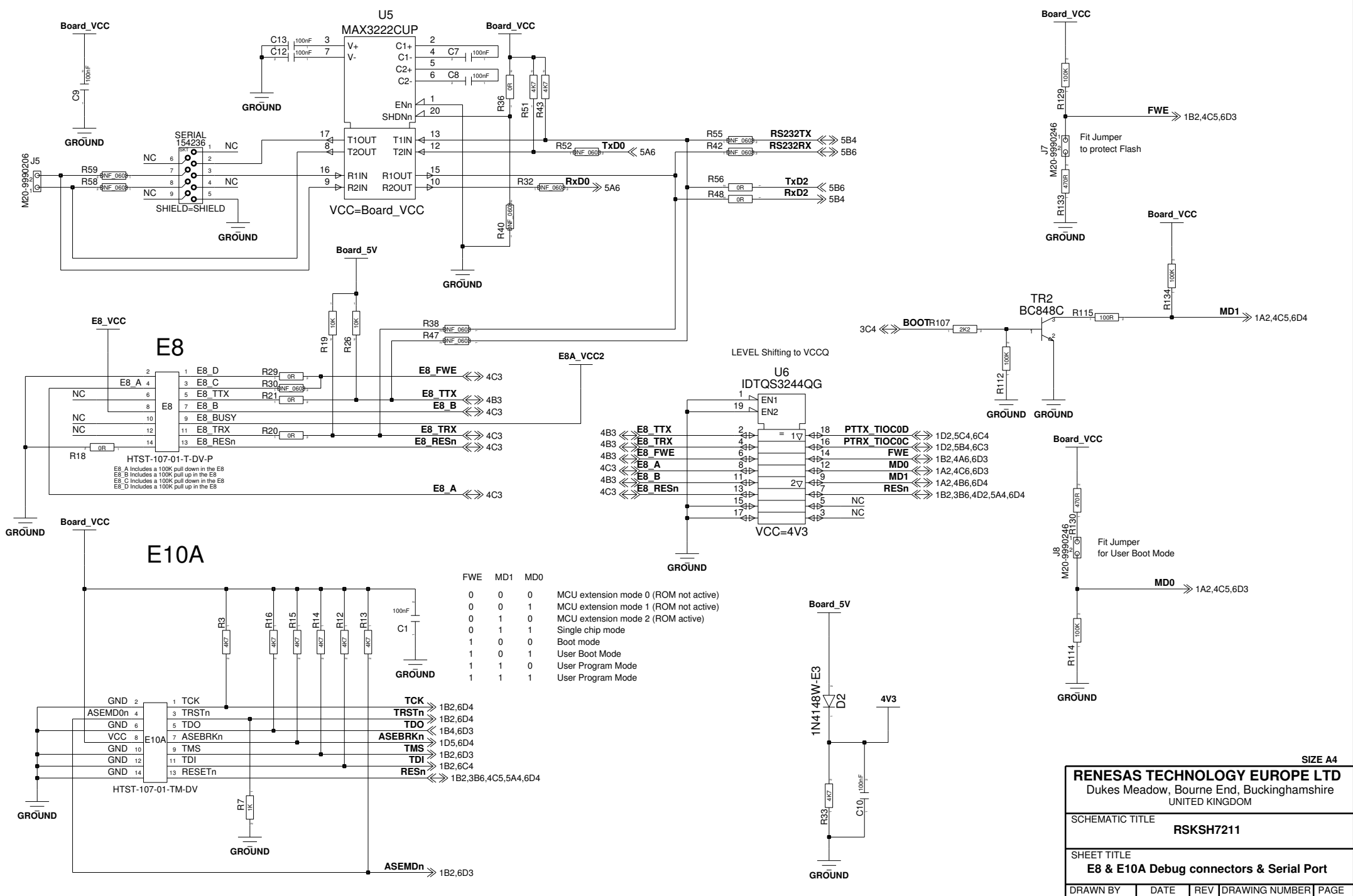

FWE	MD1	MD0	
0	0	0	MCU extension mode 0 (ROM not active)
0	0	1	MCU extension mode 1 (ROM not active)
0	1	0	MCU extension mode 2 (ROM active)
0	1	1	Single chip mode
1	0	0	Boot mode
1	0	1	User Boot Mode
1	1	0	User Program Mode
1	1	1	User Program Mode

SIZE A4

RENESAS TECHNOLOGY EUROPE LTD
 Dukas Meadow, Bourne End, Buckinghamshire
 UNITED KINGDOM

SCHEMATIC TITLE
RSKSH7211

SHEET TITLE
E8 & E10A Debug connectors & Serial Port

DRAWN BY VNA	DATE 30-11-07	REV 2.1	DRAWING NUMBER D007392_04	PAGE 4/6
-----------------	------------------	------------	------------------------------	-------------

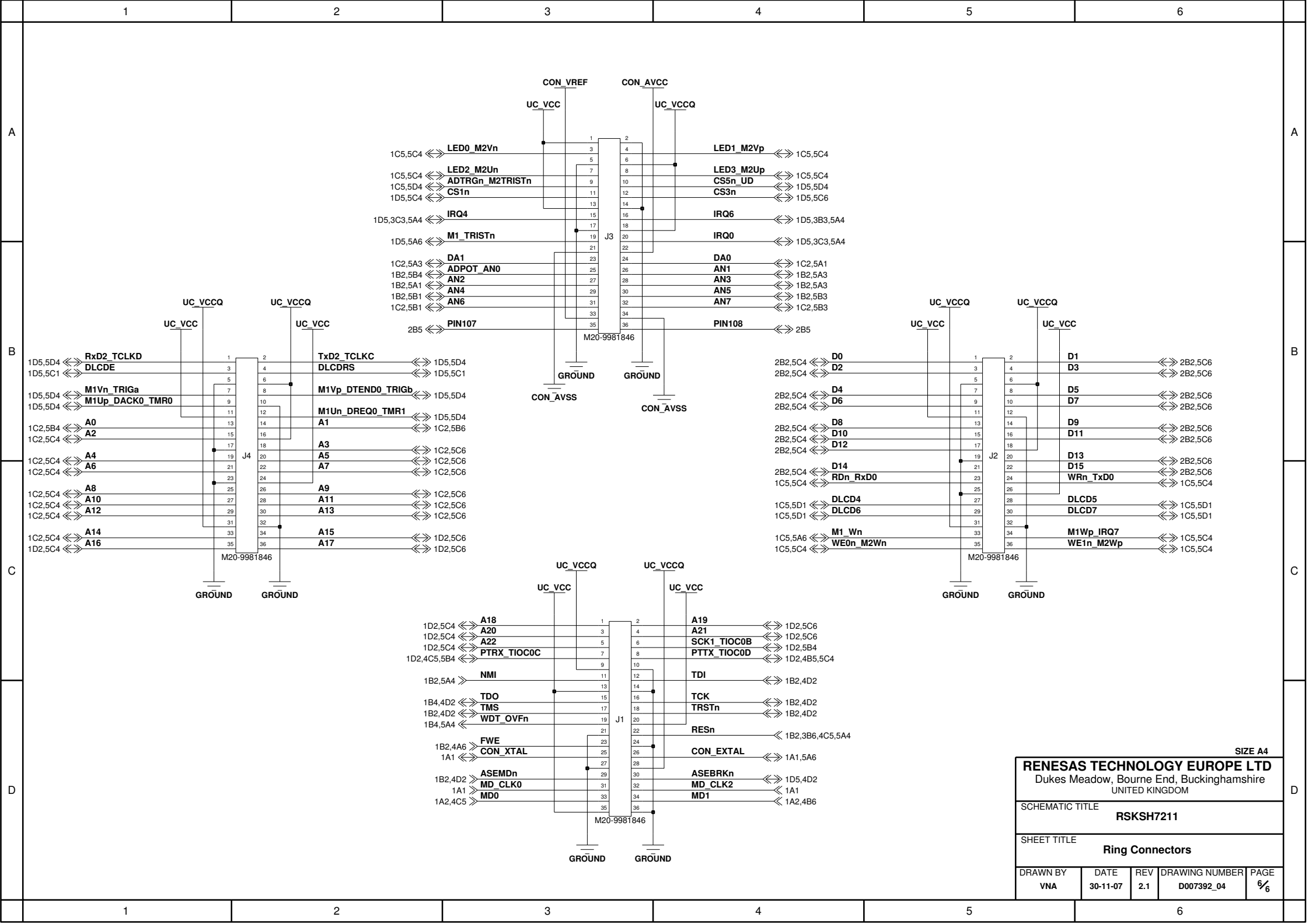

SIZE A4

RENESAS TECHNOLOGY EUROPE LTD				
Dukes Meadow, Bourne End, Buckinghamshire UNITED KINGDOM				
SCHEMATIC TITLE				
RSKSH7211				
SHEET TITLE				
Ring Connectors				
DRAWN BY	DATE	REV	DRAWING NUMBER	PAGE
VNA	30-11-07	2.1	D007392_04	6/6