

## STM32-H107 development board

## Users Manual



All boards produced by Olimex are ROHS compliant

Rev. A, December 2010

Copyright(c) 2010, OLIMEX Ltd, All rights reserved

## INTRODUCTION

**STM32-H107** header board provides easy way for developing and prototyping with the new STM32F107 connectivity line microcontroller, produced by STMicroelectronics. STM32-H107 has JTAG port for programming and debugging, USB\_OTG, user button, two status leds, and most of the GPIOs are on extension headers where you can connect your additional circuits.

## BOARD FEATURES

- CPU: STM32F107 32 bit ARM-based microcontroller with 256 KB Flash, 64KB RAM, USB OTG, Ethernet, 10 timers, 2 CANs, 2 ADCs, 14 communication interfaces
- JTAG connector with ARM 2x10 pin layout for programming/debugging
- 25 Mhz crystal
- USB\_OTG
- Power Jack
- WKUP button
- RESET button
- Two status leds
- Power-on led
- 3V battery connector
- Extension port connectors for many of microcontrollers pins
- PCB: FR-4, 1.5 mm (0,062"), soldermask, silkscreen component print
- Dimensions: 70x50mm (2.76x1.97")

## ELECTROSTATIC WARNING

The STM32-H107 board is shipped in protective anti-static packaging. The board must not be subject to high electrostatic potentials. General practice for working with static sensitive devices should be applied when working with this board.

## BOARD USE REQUIREMENTS

**Cables:** The cable you will need depends on the programmer/debugger you use. If you use [ARM-JTAG](#), you will need LPT cable, if you use [ARM-USB-OCD](#), you will need RS232 cable and 1.8 meter USB A-B cable and if you use [ARM-JTAG-EW](#), you will need 1.8 meter USB A-B cable.

**Hardware:** Programmer/Debugger – one of the Olimex ARM Programmers: ARM-JTAG, ARM-USB-OCD, ARM-JTAG-EW.

**Software:** ARM C compiler and JTAG programmer.  
Note: For OpenOCD we don't offer any projects.

## PROCESSOR FEATURES

**STM32-H107** board use ARM-based 32-bit microcontroller **STM32F107VCT6** with these features:

- Core: ARM 32-bit Cortex™-M3 CPU
  - 72 MHz maximum frequency, 1.25 DMIPS/MHz (Dhrystone 2.1) performance at 0 wait state memory access
  - Single-cycle multiplication and hardware division
- Memories
  - 256 Kbytes of Flash memory
  - 64 Kbytes of SRAM
- Clock, reset and supply management
  - 2.0 to 3.6 V application supply and I/Os
  - POR, PDR, and programmable voltage detector (PVD)
  - 25 MHz crystal oscillator
  - Internal 8 MHz factory-trimmed RC
  - Internal 40 kHz RC with calibration
  - 32 kHz oscillator for RTC with calibration
- Low power
  - Sleep, Stop and Standby modes
  - VBAT supply for RTC and backup registers
- 2 × 12-bit, 1 μs A/D converters (16 channels)
  - Conversion range: 0 to 3.6 V
  - Sample and hold capability
  - Temperature sensor
  - up to 2 MSps in interleaved mode
- 2 × 12-bit D/A converters
- DMA: 12-channel DMA controller
  - Supported peripherals: timers, ADCs, DAC, I<sup>2</sup>Ss, SPIs, I<sup>2</sup>Cs and USARTs
- Debug mode
  - Serial wire debug (SWD) & JTAG interfaces
  - Cortex-M3 Embedded Trace Macrocell™
- 80 fast I/O ports
  - 80 I/Os, all mappable on 16 external interrupt vectors and almost all 5 V-tolerant
- 10 timers
  - four 16-bit timers, each with up to 4 IC/OC/PWM or pulse counter and quadrature (incremental) encoder input

- 1 × 16-bit motor control PWM timer with dead-time generation and emergency stop
  - 2 × watchdog timers (Independent and Window)
  - SysTick timer: a 24-bit downcounter
  - 2 × 16-bit basic timers to drive the DAC
- 14 communication interfaces
  - 2 × I<sup>2</sup>C interfaces (SMBus/PMBus)
  - 5 USARTs (ISO 7816 interface, LIN, IrDA capability, modem control)
  - 3 SPIs (18 Mbit/s), 2 with a multiplexed I<sup>2</sup>S interface that offers audio class accuracy via advanced PLL schemes
  - 2 × CAN interfaces (2.0B Active) with 512 bytes of dedicated SRAM
  - USB 2.0 full-speed device/host/OTG controller with on-chip PHY that supports HNP/SRP/ID with 1.25 Kbytes of dedicated SRAM
  - 10/100 Ethernet MAC with dedicated DMA and SRAM (4 Kbytes): IEEE1588 hardware support, MII/RMII available on all packages
- CRC calculation unit, 96-bit unique ID

# BLOCK DIAGRAM

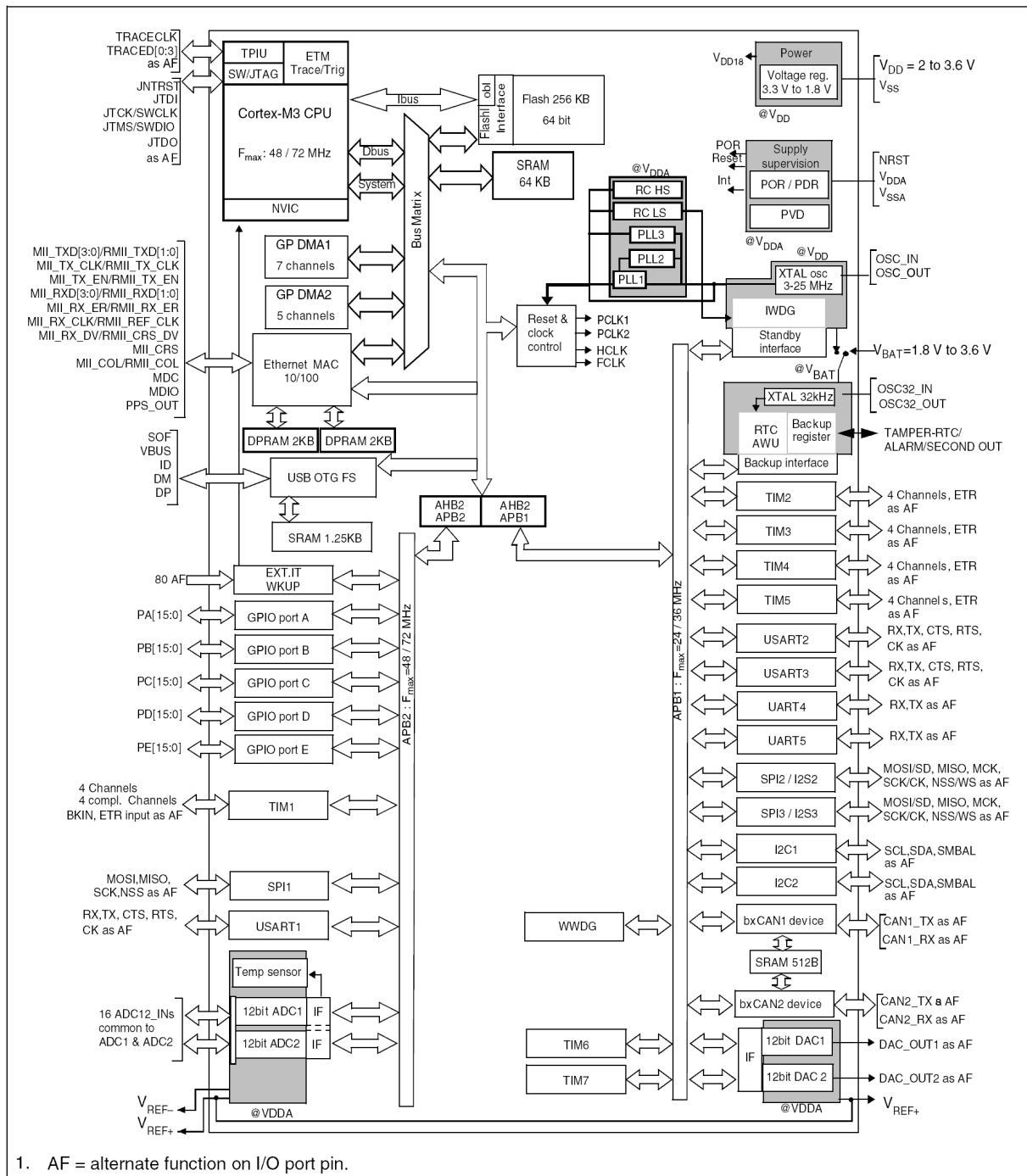

# MEMORY MAP

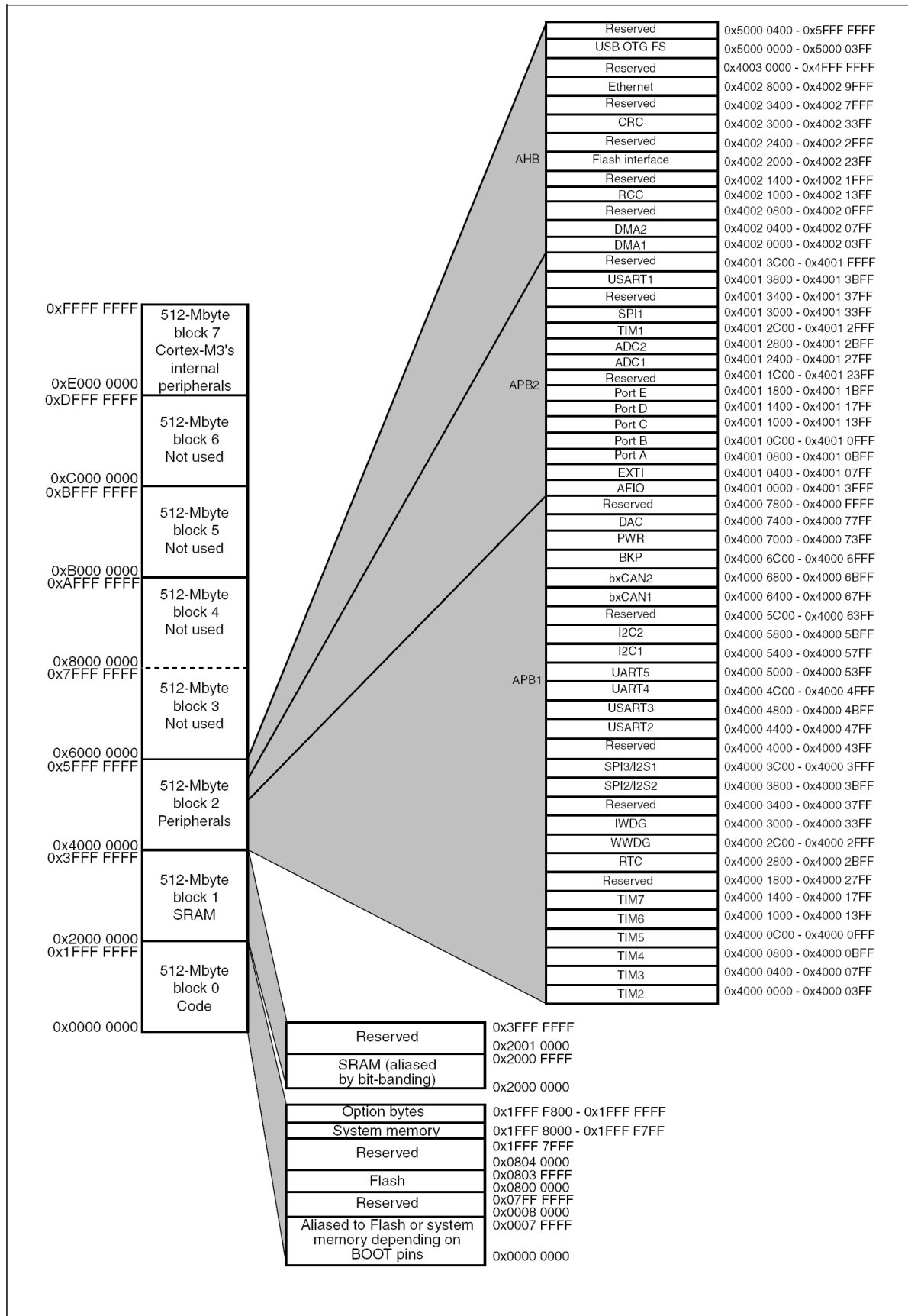

# SCHEMATIC

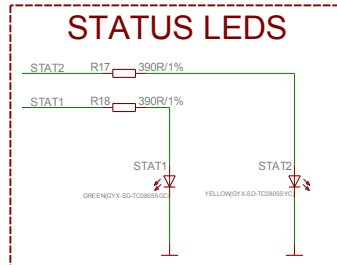
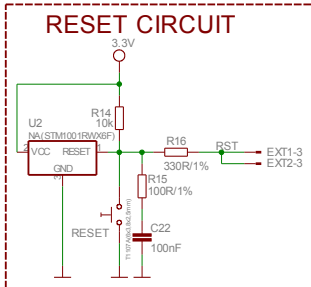
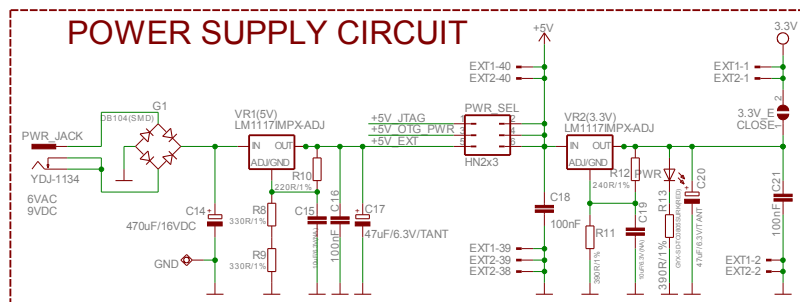
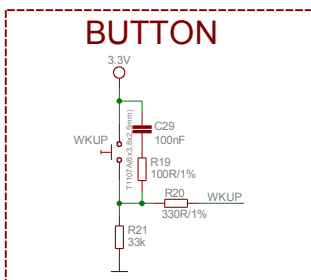
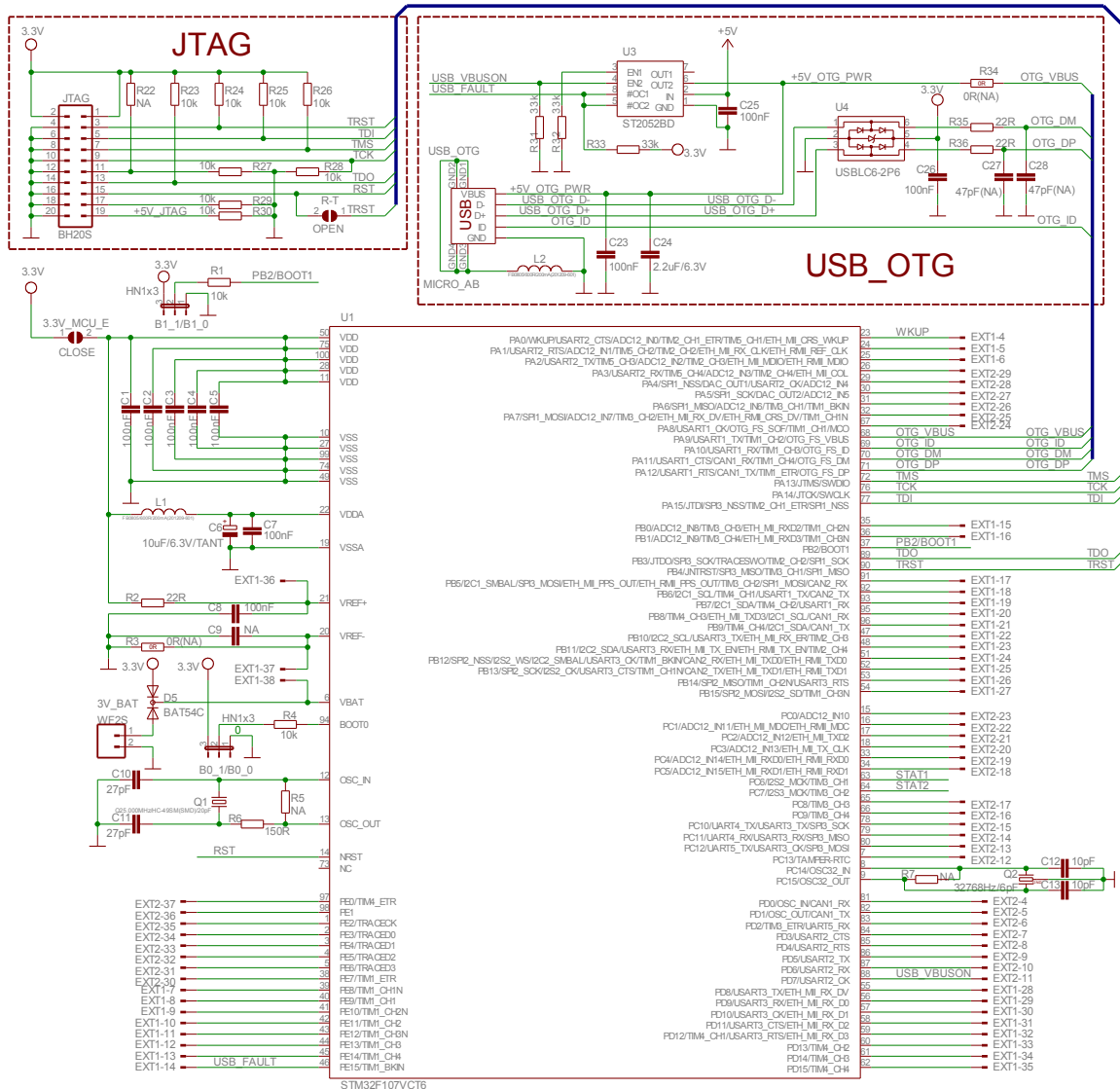

## STM32-H107

Rev. Initial  
 COPYRIGHT(C), 2009  
<http://www.dlimes.com/rev>

# BOARD LAYOUT

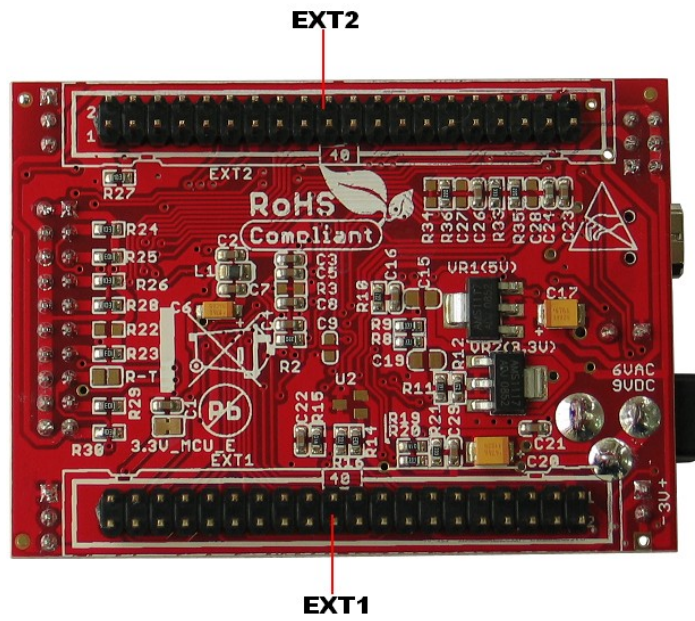
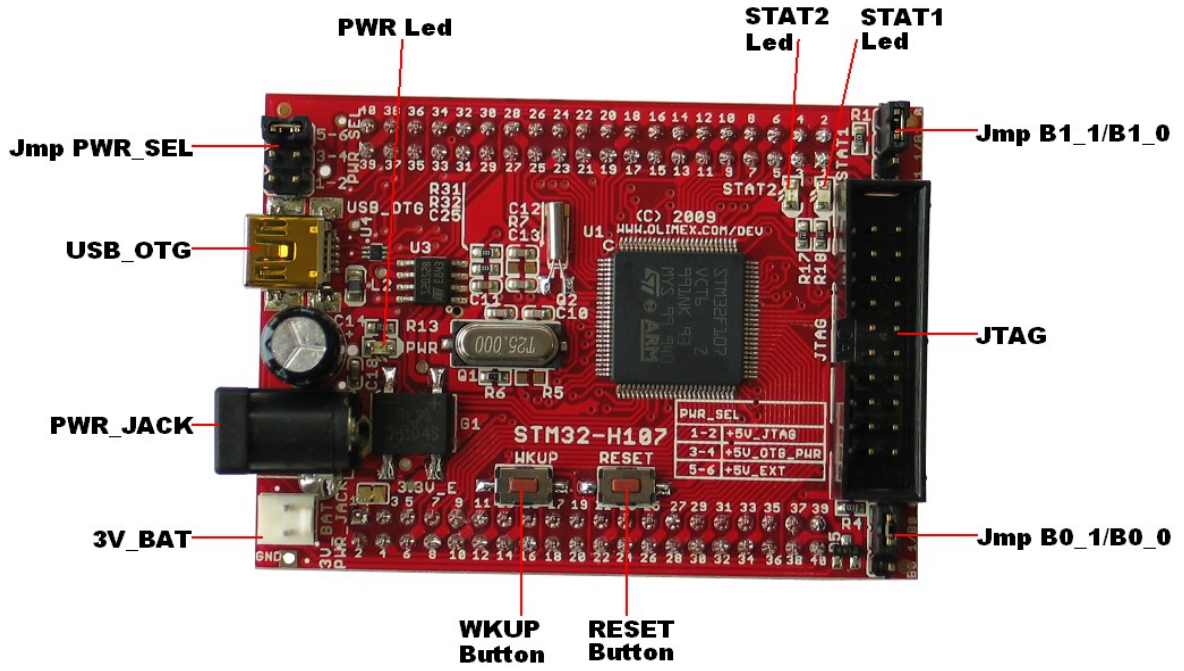

## POWER SUPPLY CIRCUIT

STM32-H107 can take power from three sources:

- PWR connector where 9 V DC or 6 V AC is applied by external power source.
- +5V\_OTG-PWR from USB OTG
- +5V\_JTAG from JTAG

## RESET CIRCUIT

STM32-H107 reset circuit includes EXT1 pin 3, EXT2 pin 3, JTAG connector pin 15, STM32F107VCT6 pin 14 (NRST) and RESET button.

## CLOCK CIRCUIT

Quartz crystal 25 MHz is connected to STM32F107 pin 12 (OSC\_IN) and pin 13 (OSC\_OUT).

Quartz crystal 32.768kHz is connected to STM32F107 pin 8 (PC14/OSC32\_IN) and pin 9 (PC15/OSC32\_OUT).

## JUMPER DESCRIPTION

### PWR\_SEL



5-6

When position 1-2 is shorted – the board is power supplied from JTAG.



3-4

When position 3-4 is shorted – the board is power supplied from USB\_OTG.



1-2

When position 5-6 is shorted – the board is power supplied from External power source.

Default state is – position 5-6 – shorted.

### B0\_1/B0\_0



When this jumper is in position B0\_1 – BOOT0 is connected to 3.3V, and when the jumper is in position B0\_0 – BOOT0 is connected to GND.

Default state is B0\_0.

### B1\_1/B1\_0



When this jumper is in position B1\_1 – BOOT1 is connected to 3.3V, and when the jumper is in position B1\_0 – BOOT1 is connected to GND.

Default state is B1\_0.

### 3.3V\_MCU\_E



Enable 3.3V microcontroller power supply

Default state is closed.

### 3.3V\_E



Enable regulator VR2 (3.3V) - LM1117

Default state is closed.

### R-T



Connects RST to TRST

Default state is open.

## INPUT/OUTPUT

**Status LED1 (green)** with name **STAT1** connected to STM32F107VCT6 pin 63 (PC6/I2S2\_MCK/TIM3\_CH1).

**Status LED2 (yellow)** with name **STAT2** connected to STM32F107VCT6 pin 64 (PC7/I2S3\_MCK/TIM3\_CH2).

**Power-on LED (red)** with name **PWR** - this led shows that +3.3V is applied to the board.

**User button** with name **WKUP** connected to STM32F107VCT6 pin 23 (PA0/WKUP).

**Reset button** with name **RESET** connected to STM32F107VCT6 pin 14 (NRST).

## CONNECTOR DESCRIPTIONS

### JTAG:

The JTAG connector allows the software debugger to talk via a JTAG (Joint Test Action Group) port directly to the core. Instructions may be inserted and executed by the core thus allowing STM32F107VCT6 memory to be programmed with code and executed step by step by the host software.

For more details refer to IEEE Standard 1149.1 - 1990 Standard Test Access Port and Boundary Scan Architecture and STM32F107VCT6 datasheets and users manual.

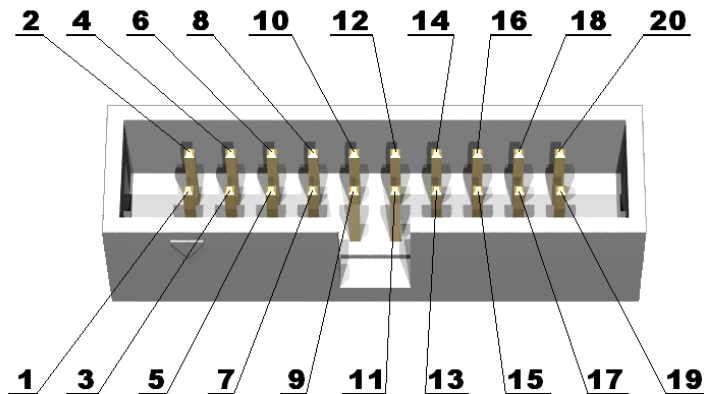

Pin #	Signal Name	Pin #	Signal Name
1	3.3V	2	3.3V
3	TRST	4	GND
5	TDI	6	GND
7	TMS	8	GND
9	TCK	10	GND

11	PULL-DOWN	12	GND
13	TDO	14	GND
15	RST	16	GND
17	PULL-DOWN	18	GND
19	+5V_JTAG	20	GND

### PWR JACK:

Pin #	Signal Name
1	Power Input
2	GND

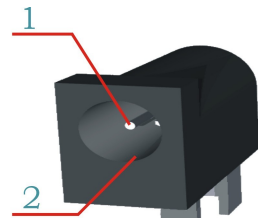

### USB OTG

Pin #	Signal Name
1	+5V_OTG_PWR
2	USB_OTG_D-
3	USB_OTG_D+
4	OTG_ID
5	GND

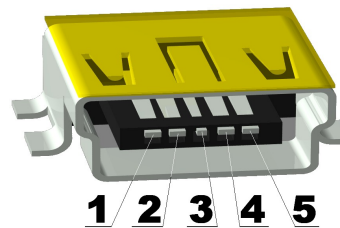

### 3V BAT

Pin #	Signal Name
1	VBAT
2	GND

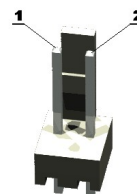

## EXT1

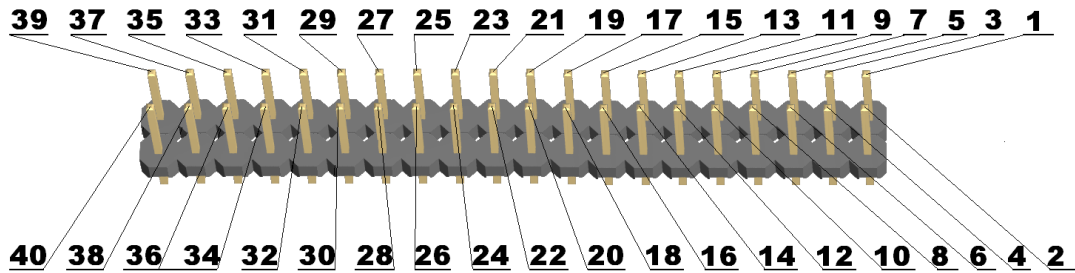

Pin #	Signal Name	Pin #	Signal Name
1	3.3V	2	GND
3	RST	4	WKUP
5	EXT1-5	6	EXT1-6
7	EXT1-7	8	EXT1-8
9	EXT1-9	10	EXT1-10
11	EXT1-11	12	EXT1-12
13	EXT1-13	14	USB_FAULT
15	EXT1-15	16	EXT1-16
17	EXT1-17	18	EXT1-18
19	EXT1-19	20	EXT1-20
21	EXT1-21	22	EXT1-22
23	EXT1-23	24	EXT1-24
25	EXT1-25	26	EXT1-26
27	EXT1-27	28	EXT1-28
29	EXT1-29	30	EXT1-30
31	EXT1-31	32	EXT1-32
33	EXT1-33	34	EXT1-34
35	EXT1-35	36	VREF+
37	VREF-	38	VBAT
39	GND	40	+5V

## EXT2

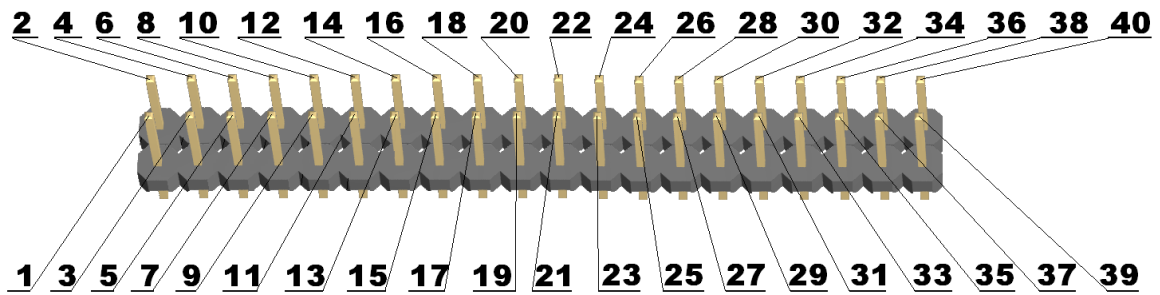

Pin #	Signal Name	Pin #	Signal Name
1	3.3V	2	GND
3	RST	4	EXT2-4
5	EXT2-5	6	EXT2-6
7	EXT2-7	8	EXT2-8
9	EXT2-9	10	EXT2-10
11	USB_VBUSON	12	EXT2-12
13	EXT2-13	14	EXT2-14
15	EXT2-15	16	EXT2-16
17	EXT2-17	18	EXT2-18
19	EXT2-19	20	EXT2-20
21	EXT2-21	22	EXT2-22
23	EXT2-23	24	EXT2-24
25	EXT2-25	26	EXT2-26
27	EXT2-27	28	EXT2-28
29	EXT2-29	30	EXT2-20
31	EXT2-31	32	EXT2-32
33	EXT2-33	34	EXT2-34
35	EXT2-35	36	EXT2-36
37	EXT2-37	38	GND
39	GND	40	+5V

# MECHANICAL DIMENSIONS

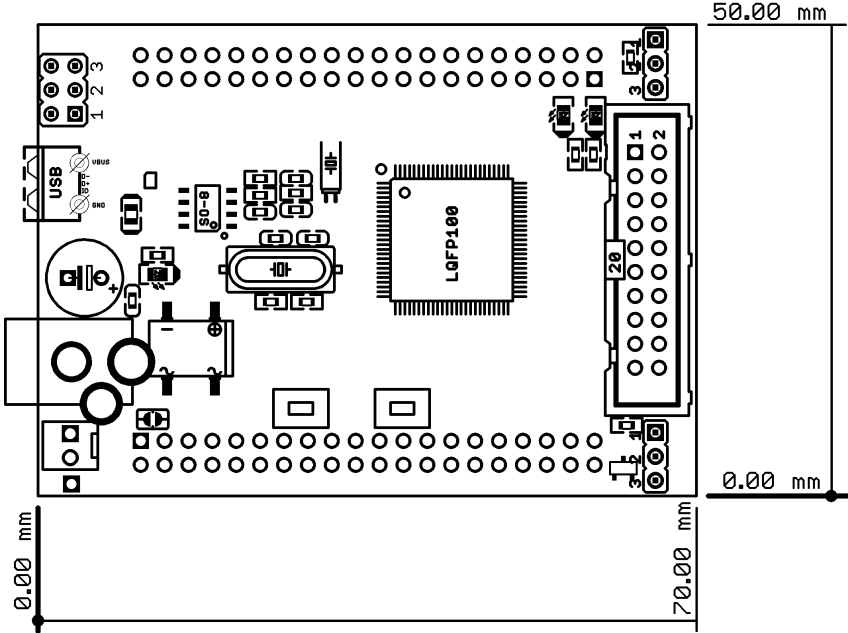

## **AVAILABLE DEMO SOFTWARE**

- STM32F107\_leds
- STM32H107\_usb\_OTG

## ORDER CODE

**STM32-H107** – assembled and tested (no kit, no soldering required)

How to order?

You can order to us directly or by any of our distributors.

Check our web [www.olimex.com/dev](http://www.olimex.com/dev) for more info.

### Revision history:

REV. Initial	- create November 2009
REV.A	- edited by TU

**Disclaimer:**

© 2009 Olimex Ltd. All rights reserved. Olimex®, logo and combinations thereof, are registered trademarks of Olimex Ltd. Other terms and product names may be trademarks of others.

The information in this document is provided in connection with Olimex products. No license, express or implied or otherwise, to any intellectual property right is granted by this document or in connection with the sale of Olimex products.

Neither the whole nor any part of the information contained in or the product described in this document may be adapted or reproduced in any material from except with the prior written permission of the copyright holder.

The product described in this document is subject to continuous development and improvements. All particulars of the product and its use contained in this document are given by OLIMEX in good faith. However all warranties implied or expressed including but not limited to implied warranties of merchantability or fitness for purpose are excluded.

This document is intended only to assist the reader in the use of the product. OLIMEX Ltd. shall not be liable for any loss or damage arising from the use of any information in this document or any error or omission in such information or any incorrect use of the product.